

CMOS Analog Switches

Features

- $\pm 15\text{-V}$ Input Range
- Low $r_{DS(on)}$: $30\ \Omega$
- Single Supply Operation
- Pin and Function Compatible with the JFET DG180 Family

Benefits

- Full Rail-to-Rail Analog Signal Range
- Minimizes Signal Error
- Low Power Dissipation

Applications

- Low Level Switching Circuits
- Programmable Gain Amplifiers
- Portable and Battery Powered Systems

Description

The DG381A–DG390A series of monolithic CMOS analog switches was designed for applications in instrumentation, communications, and process control. This series is suited for applications requiring fast switching and nearly flat on-resistance over the entire voltage range.

Designed on Siliconix' PLUS-40 CMOS process, these devices achieve low power consumption (3.5 mW typical) and excellent on/off switch performance.

These switches are ideal for battery powered applications, without sacrificing switching speed. Break-before-make switching action is guaranteed, and an epitaxial layer prevents latchup. Single supply operation is allowed by connecting the V– rail to 0 V.

Each switch conducts equally well in both directions when on, and blocks up to the supply voltage when off. These switches are CMOS and quasi TTL logic compatible.

Functional Block Diagram and Pin Configuration

DG381A

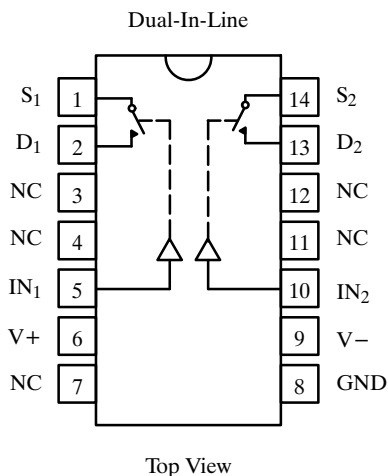

Truth Table

Logic	Switch
0	ON
1	OFF

Logic "0" $\leq 0.8\text{ V}$
 Logic "1" $\geq 4\text{ V}$

Switches Shown for Logic "1" Input

Ordering Information – DG381A

Temp Range	Package	Part Number
0 to 70°C	14-Pin Plastic DIP	DG381ACJ
–55 to 125°C	14-Pin CerDIP	DG381AAK/883

DG381A/384A/387A/390A

Functional Block Diagram and Pin Configuration (Cont'd)

DG384A

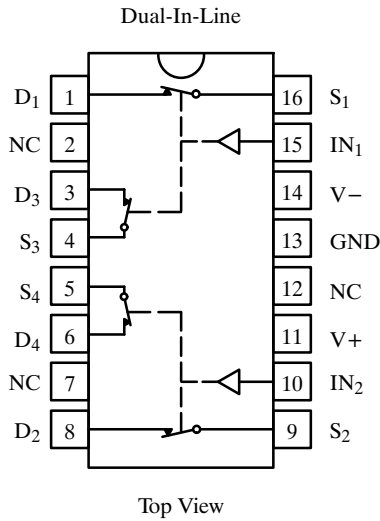

Truth Table

Logic	Switch
0	OFF
1	ON

Logic "0" ≤ 0.8 V

Logic "1" ≥ 4 V

Switches Shown for Logic "1" Input

Ordering Information – DG384A

Temp Range	Package	Part Number
0 to 70°C	16-Pin Plastic DIP	DG384ACJ
-55 to 125°C	16-Pin CerDIP	DG384AAK/883

DG387A

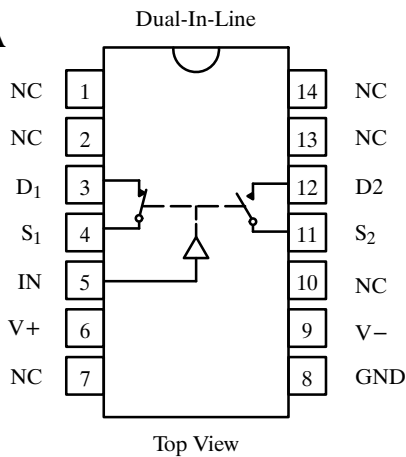

Truth Table

Logic	SW ₁ , SW ₂	SW ₃ , SW ₄
0	OFF	ON
1	ON	OFF

Logic "0" ≤ 0.8 V

Logic "1" ≥ 4 V

Switches Shown for Logic "1" Input

Ordering Information – DG387A

Temp Range	Package	Part Number
0 to 70°C	14-Pin Plastic DIP	DG387ACJ
-55 to 125°C	14-Pin CerDIP	DG387AAK/883
	10-Pin Metal Can	DG387AAA/883

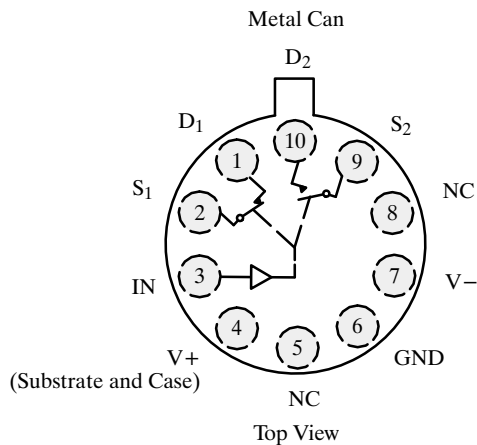

Functional Block Diagram and Pin Configuration (Cont'd)

DG390A

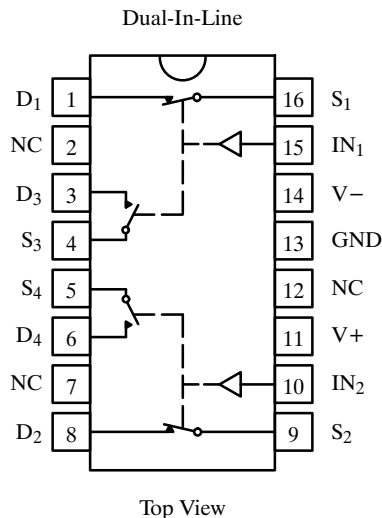

Truth Table

Logic	SW ₁ , SW ₂	SW ₃ , SW ₄
0	OFF	ON
1	ON	OFF

Logic "0" ≤ 0.8 V
Logic "1" ≥ 4 V

Switches Shown for Logic "1" Input

Ordering Information – DG390A

Temp Range	Package	Part Number
0 to 70°C	16-Pin Plastic DIP	DG390ACJ
-25 to 85°C	16-Pin CerDIP	DG390ABK
		DG390AAK
		DG390AAK/883
-55 to 125°C		

Absolute Maximum Ratings

Voltages Referenced to V-

V+	44 V
GND	25 V
Digital Inputs ^a , V _S , V _D	(V-) -2 V to (V+) +2V or 30 mA, whichever occurs first
Current, Any Terminal Except S or D	30 mA
Continuous Current, S or D	30 mA
(Pulsed at 1 ms, 10% duty cycle max)	100 mA
Storage Temperature	(AAA, AAK, ACK Suffix) -65 to 150°C
(ACJ Suffix)	-65 to 125°C

Power Dissipation^b

14-Pin Plastic DIP ^d	470 mW
14-Pin CerDIP ^c	825 mW
10-Pin Metal Can ^e	450 mW

Notes:

- Signals on S_X, D_X, or IN_X exceeding V+ or V- will be clamped by internal diodes. Limit forward diode current to maximum current ratings.
- All leads welded or soldered to PC Board.
- Derate 11 mW/°C above 75°C
- Derate 6.5 mW/°C above 25°C
- Derate 6 mW/°C above 75°C

Specifications^a

Parameter	Symbol	Test Conditions Unless Otherwise Specified V+ = 15 V, V- = -15 V V _{IN} = 0.8 V or 4 V ^f	Temp ^b	Typ ^c	A Suffix -55 to 125°C		B, C Suffix 0 to 70°C -25 to 85°C		Unit
					Min ^d	Max ^d	Min ^d	Max ^d	
Analog Switch									
Analog Signal Range ^e	V _{ANALOG}		Full		-15	15	-15	15	V
Drain-Source On-Resistance	r _{DS(on)}	V _D = ±10 V, I _S = -10 mA	Room Full	30		50 75		50 75	Ω
Source Off Leakage Current	I _{S(off)}	V _S = ±14 V, V _D = ∓14 V	Room Hot	±0.1	-1 -100	1 100	-5 -100	5 100	nA
Drain Off Leakage Current	I _{D(off)}	V _S = ±14 V, V _D = ∓14 V	Room Hot	±0.1	-1 -100	1 100	-5 -100	5 100	
Drain On Leakage Current	I _{D(on)}	V _D = V _S = ±14 V	Room Hot	±0.1	-11 -100	1 100	-5 -100	5 100	

DG381A/384A/387A/390A

Specifications^a

Parameter	Symbol	Test Conditions Unless Otherwise Specified $V_+ = 15\text{ V}, V_- = -15\text{ V}$ $V_{IN} = 0.8\text{ V}$ or 4 V^f		Temp ^b	Typ ^c	A Suffix -55 to 125°C		B, C Suffix 0 to 70°C -25 to 85°C		Unit
						Min ^d	Max ^d	Min ^d	Max ^d	
Digital Control										
Input Current with Input Voltage High	I_{INH}	$V_{IN} = 5\text{ V}$		Room Full	-0.0 01	-1 -1		-1		μA
		$V_{IN} = 15\text{ V}$		Room Full	0.00 1		1 1		1	
Input Current with Input Voltage Low	I_{INL}	$V_{IN} = 0\text{ V}$		Room Full	-0.0 01	-1 -1		-1		
Dynamic Characteristics										
Turn-On Time	t_{ON}	See Figure 2		Room	150		300			ns
Turn-Off Time	t_{OFF}			Room	130		250			
Break-Before-Make Time	t_{OPEN}	See Figure 3		Room	50					
Charge Injection	Q	$C_L = 0.01\ \mu\text{F}, R_{gen} = 0\ \Omega, V_{gen} = 0\text{ V}$		Room	10					pC
Source-Off Capacitance	$C_{S(off)}$	$f = 1\text{ MHz}; V_S, V_D = 0\text{ V}$		Room	14					pF
Drain-Off Capacitance	$C_{D(off)}$			Room	14					
Channel-On Capacitance	$C_{D(on)}$			Room	40					
Input Capacitance	C_{IN}	$f = 1\text{ MHz}$	$V_{IN} = 0\text{ V}$	Room	6					
			$V_{IN} = 15\text{ V}$	Room	7					
Off-Isolation	OIRR	$V_{IN} = 0\text{ V}, R_L = 1\text{ k}\Omega$ $V_S = 1\text{ V}_{rms}, f = 500\text{ kHz}$		Room	62					dB
Crosstalk (Channel-to-Channel)	X_{TALK}			Room	74					
Power Supplies										
Positive Supply Current	I_+	$V_{IN} = 4\text{ V}$ (One Input) (All Others = 0)		Room Full	0.23		0.5 1.0		1	mA
Negative Supply Current	I_-			Room Full	-0.0 01	-10 -100		-100		
Positive Supply Current	I_+	$V_{IN} = 0.8\text{ V}$ (All Inputs)		Room Full	0.00 1		10 100		100	μA
Negative Supply Current	I_-			Room Full	-0.0 01	-10 -100		-100		

Notes:

- Refer to PROCESS OPTION FLOWCHART (Section 5 of the 1994 Data Book or FaxBack number 7103).
- Room = 25°C, Full = as determined by the operating temperature suffix.
- Typical values are for DESIGN AID ONLY, not guaranteed nor subject to production testing.
- The algebraic convention whereby the most negative value is a minimum and the most positive a maximum, is used in this data sheet.
- Guaranteed by design, not subject to production test.
- V_{IN} = input voltage to perform proper function.

Typical Characteristics

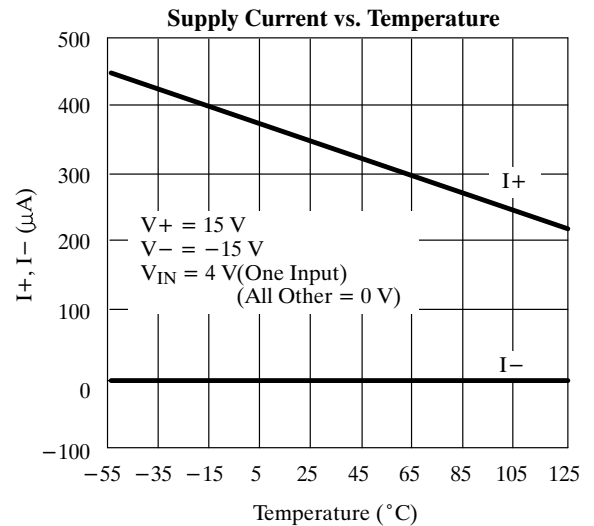
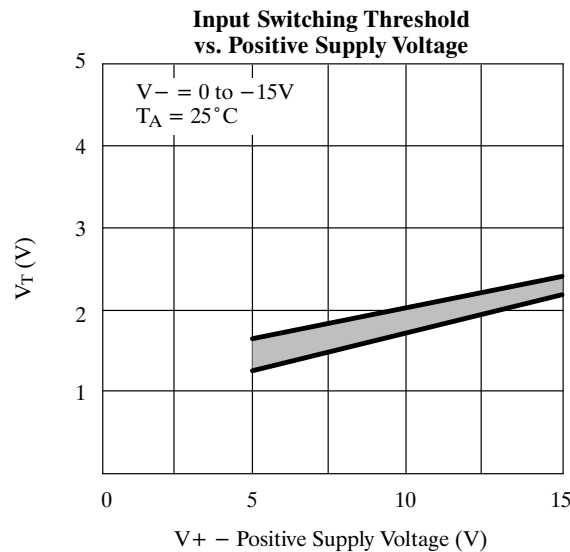
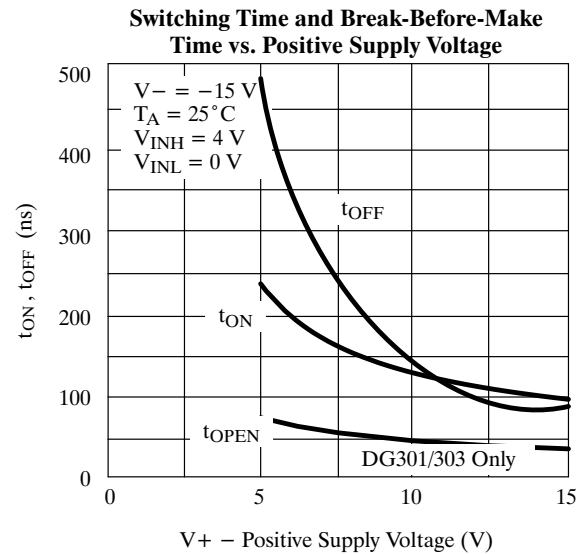
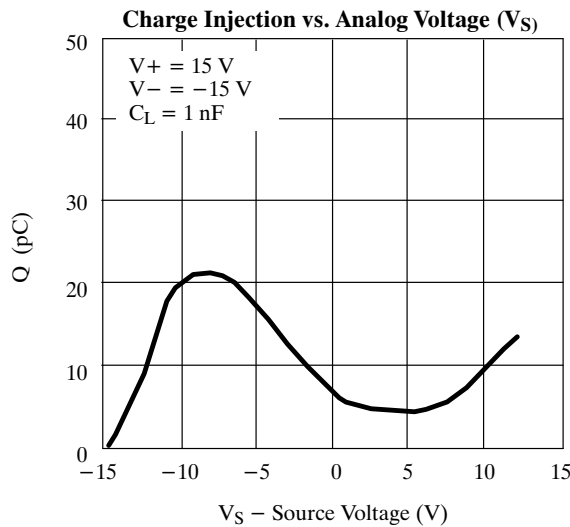
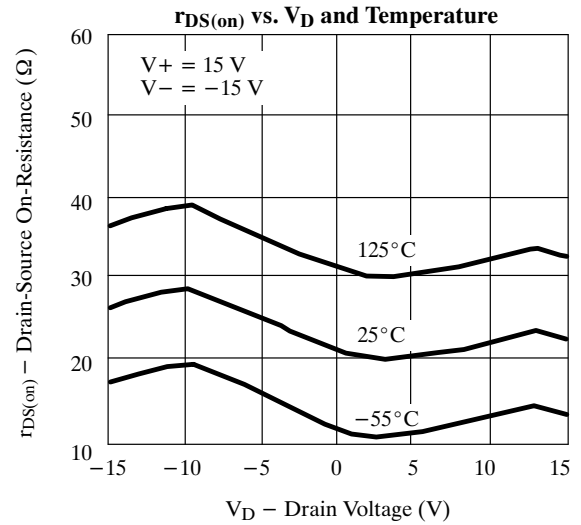
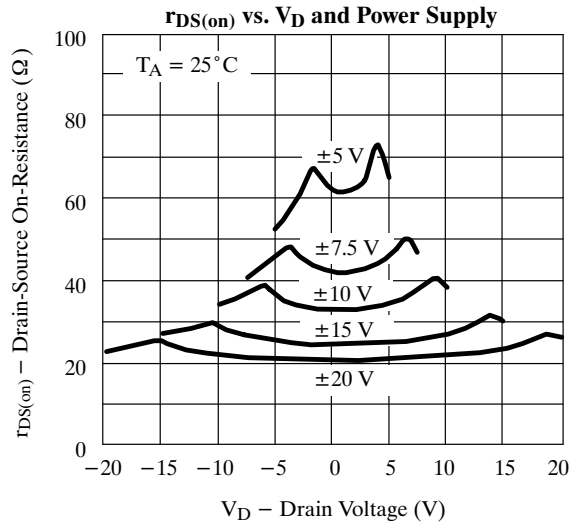

DG381A/384A/387A/390A

Typical Characteristic (Cont'd)

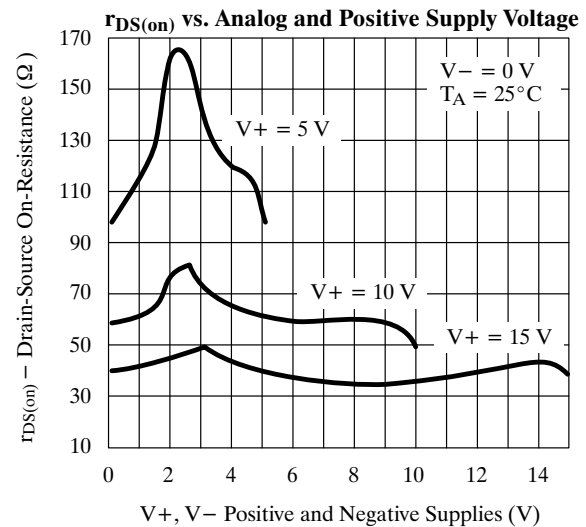
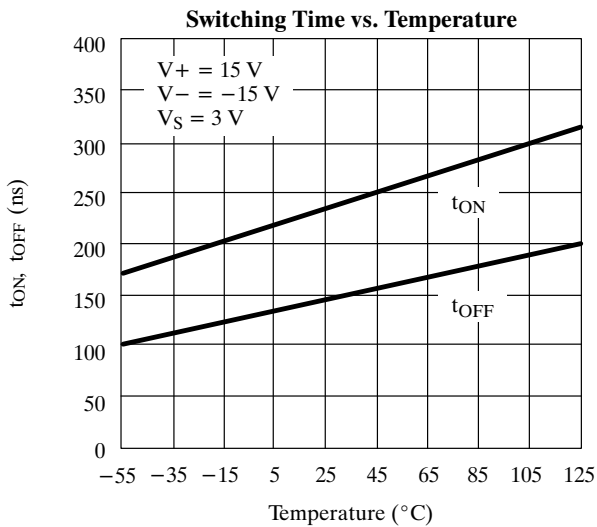
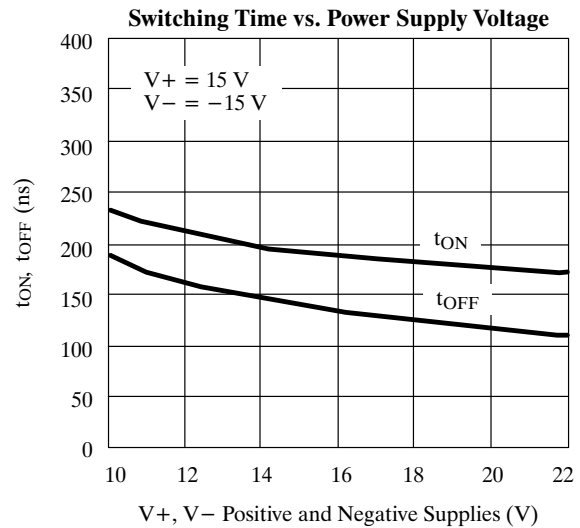
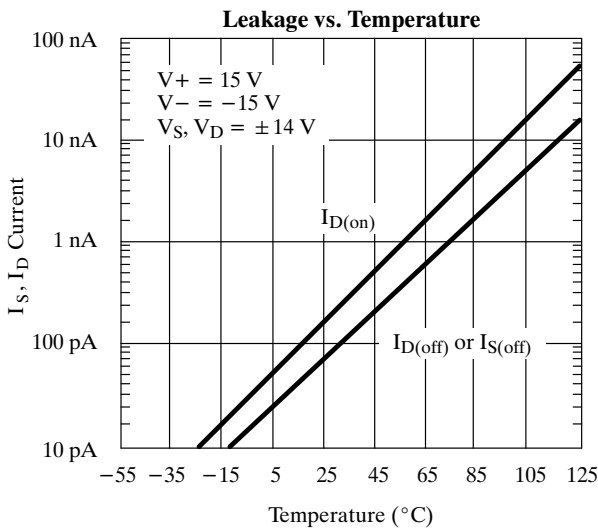
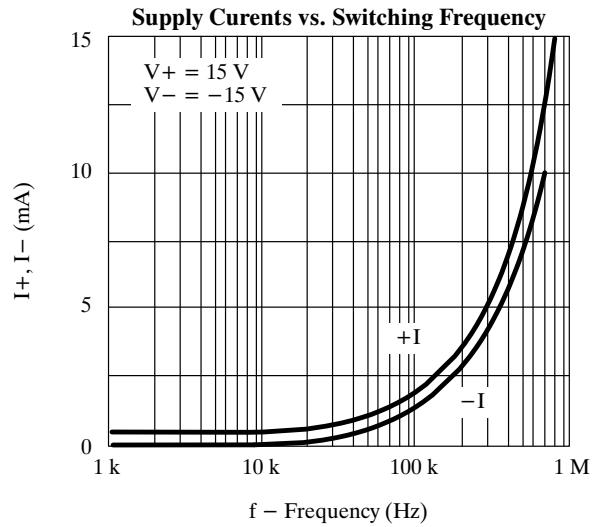
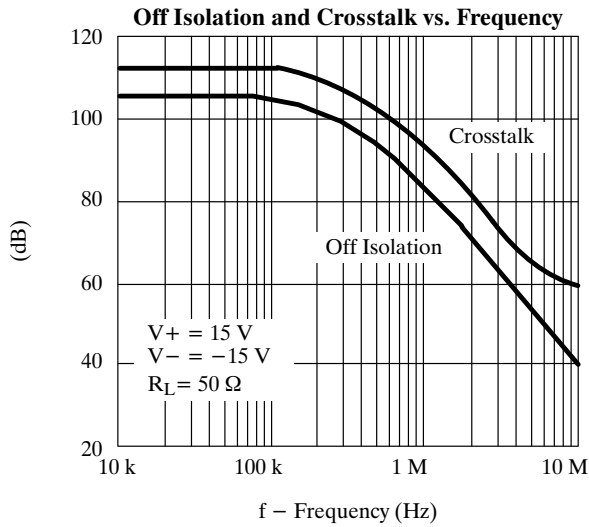

Schematic Diagram (Typical Channel)

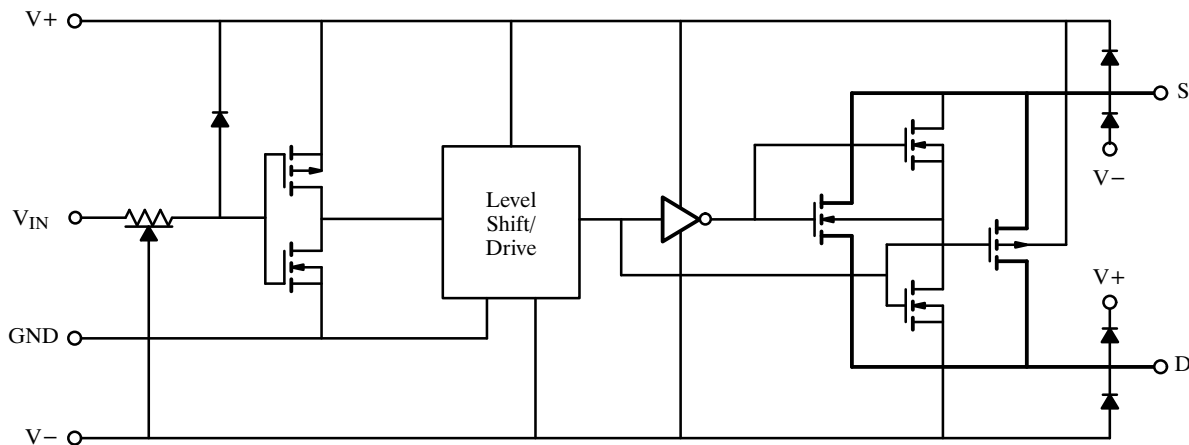

Figure 1.

Test Circuits

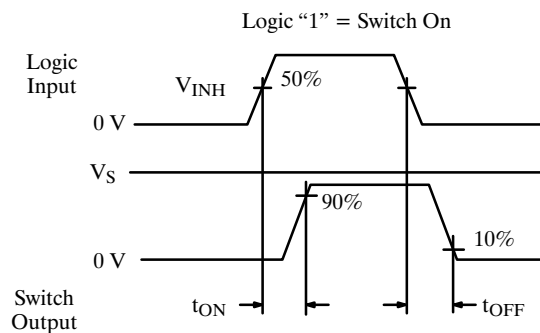
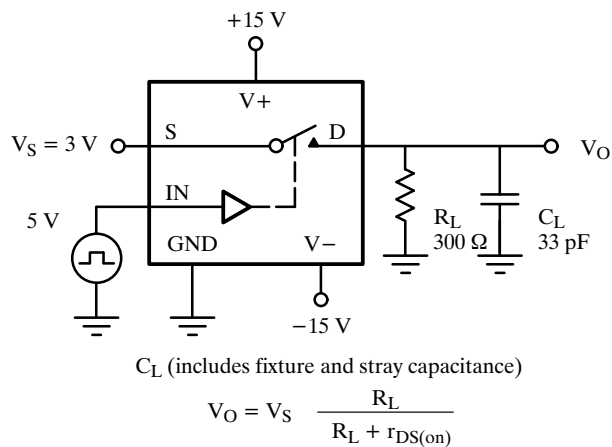

Figure 2. Switching Time

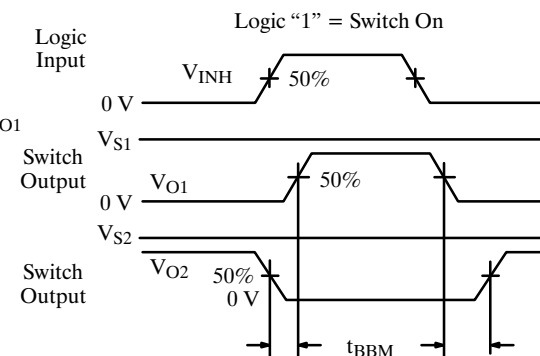
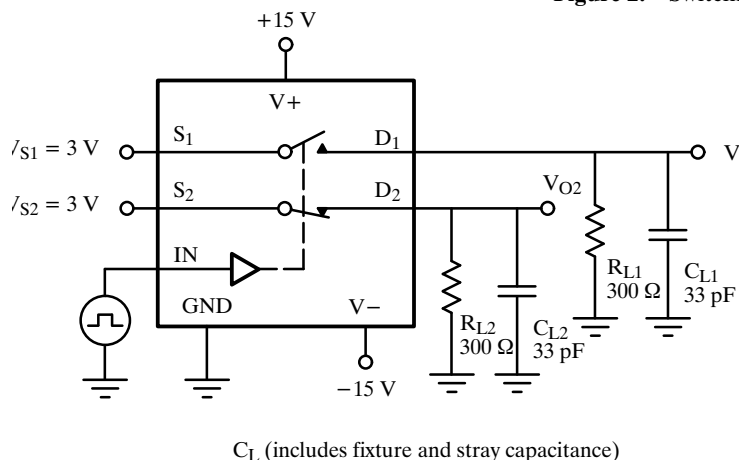

Figure 3. Break-Before-Make SPDT (DG301A, DG303A)

DG381A/384A/387A/390A

Test Circuits (Cont'd)

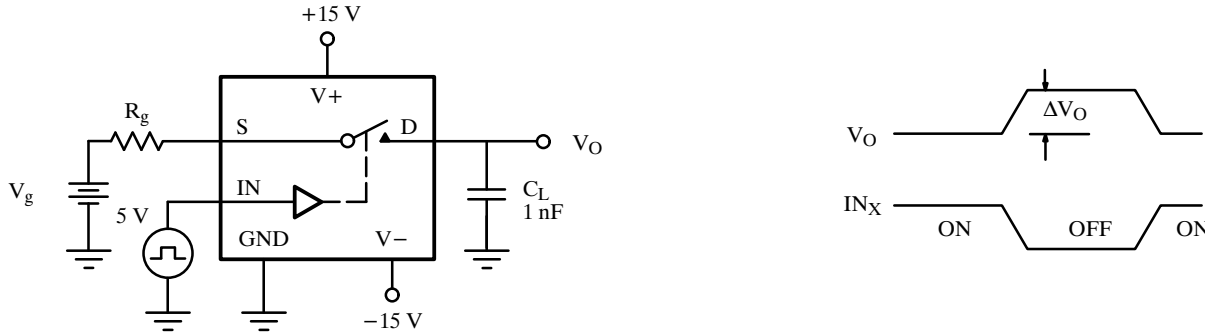

Figure 4. Charge Injection

Applications

The DG381A series of analog switches will switch positive analog signals while using a single positive supply. This allows their use in applications where only one supply is available. The trade-offs or performance given up while using single supplies are: 1) increased $r_{DS(on)}$, 2) slower switching speed. Typical curves for aid in designing with single supplies are supplied (see Typical Characteristics). The analog voltage should not go above or below the supply voltages which in single operation are $V+$ and 0 V .

In the integrator of Figure 4, R_D controls the discharge rate of the capacitor so that the pulsed or continuous current ratings are not exceeded. During reset SW_1 is closed and SW_2 is open. Opening SW_2 with SW_1 also open will hold the integrator output at its present value.

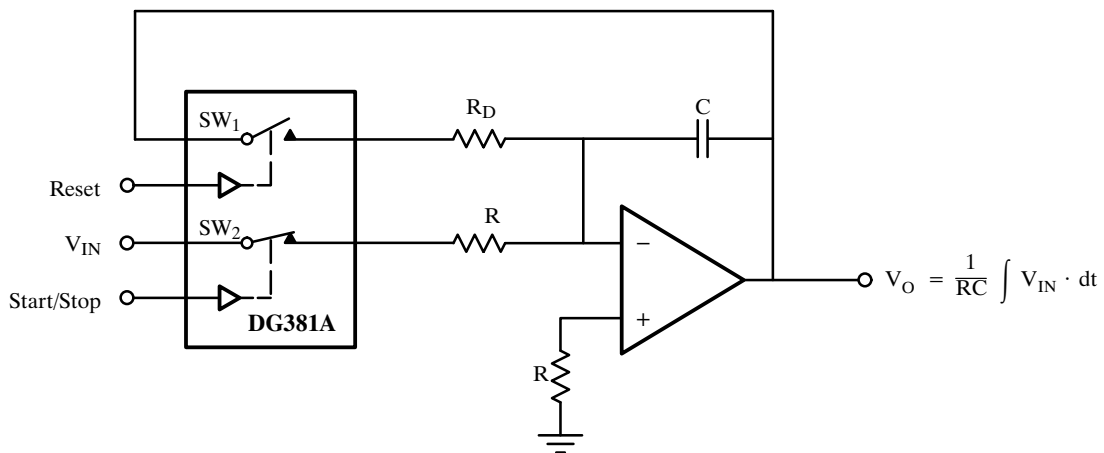

Figure 5. Integrator with Reset and Start/Stop